



**Experts in Bottle Cleaning Machinery, Engineering and Fabrication Services**

## HS-600 GRIPPER BOTTLE CLEANER

High speed cleaning/rinsing demands stable bottle handling. The HS-600 has been designed to handle heavier/larger containers/bottles at speeds of up to 540bpm (for a standard 8oz bottle). The HS-600 is designed to clean the inside of empty bottles utilizing air, water, sanitizer, or any combination of the three. Enjoy positive container handling with built-in infeed/discharge conveyors and soft rubber gripper belting. This machine features no change parts for new size bottles and a low profile, making the HS-600 the ideal cleaner/rinser of today's marketplace.

### Special Features

- Bottles are inverted and rinsed via a series of stationary nozzles
- No Change Parts. Changeovers are quick and easy, simply adjust belting and guide rails to accommodate new bottles
- Soft rubber grippers gently squeeze and invert containers, running them through a rinse cycle with soft starts and stops
- High Speed Cleaning. Capable of reaching speeds of up to 540bpm



E: [sales@mcbradyengineering.com](mailto:sales@mcbradyengineering.com)

T: 815-744-8900

[www.mcbradyengineering.com](http://www.mcbradyengineering.com)

1251 S. Larkin Ave. Joliet, IL 60436



# MCBRADY ENGINEERING, INC.

Experts in Bottle Cleaning Machinery, Engineering and Fabrication Services

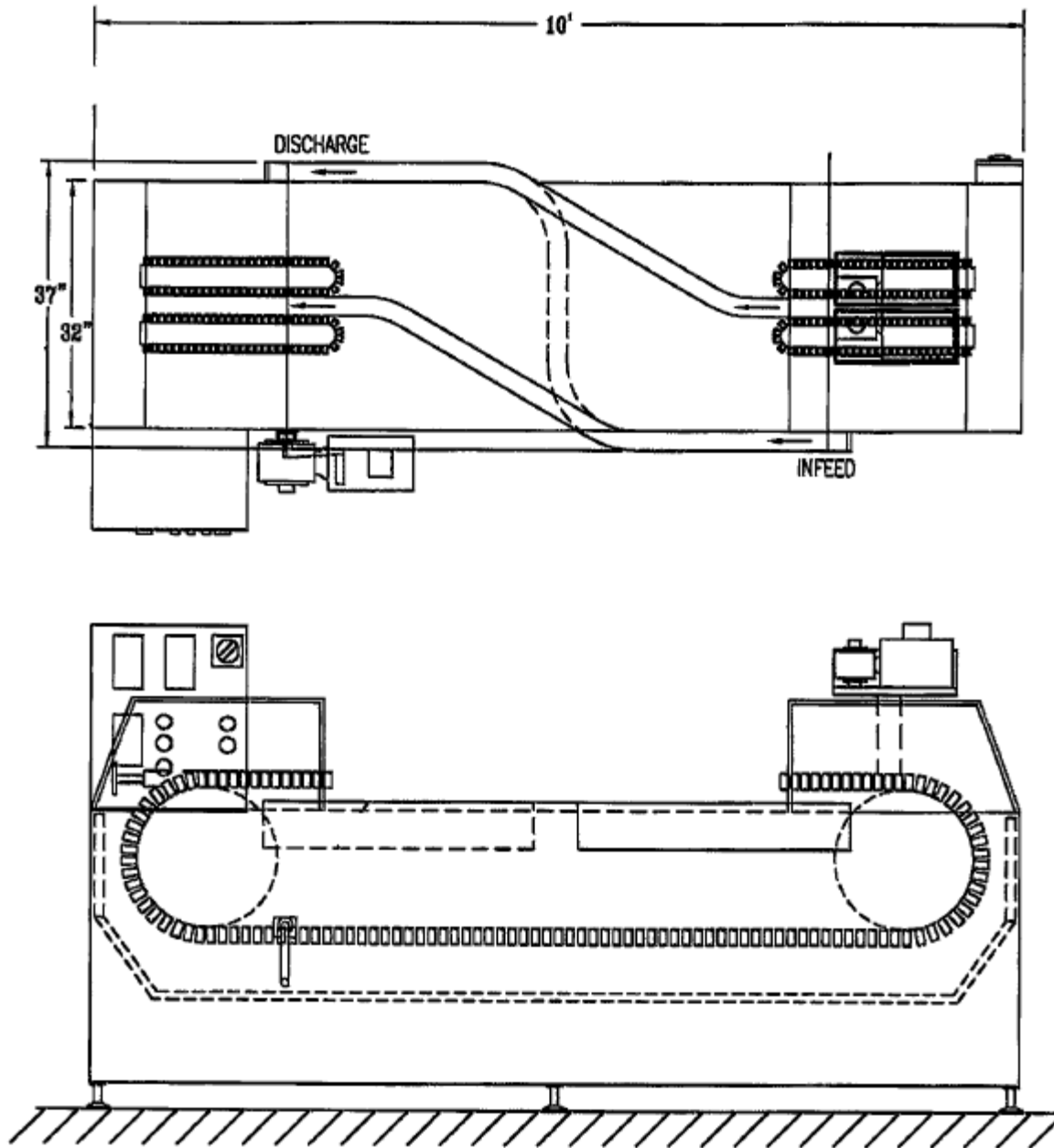

E: [sales@mcbradyengineering.com](mailto:sales@mcbradyengineering.com)

[www.mcbradyengineering.com](http://www.mcbradyengineering.com)



T: 815-744-8900

1251 S. Larkin Ave. Joliet, IL 60436