



Experts in Bottle Cleaning Machinery, Engineering and Fabrication Services

Model #42 Exterior Rinse Tunnel

The Model #42 Exterior Rinse Tunnel offers the perfect solution for cleaning the exterior of bottles, cans, and containers. Capable of rinsing with air, water, sanitizer, or any combination of the three, the Model #42 Exterior Rinse Tunnel excels in removing external dust, debris, and contaminants. The tunnel is designed to mount around an existing conveyor and comes completely enclosed to ensure that no contaminants escape into the surrounding environment. Available in any desirable length (6', 8', 10'...) this tunnel is an easy integration into a new or existing line. This machine is a great alternative to one of our state-of-the-art Bottle Dusters.

Special Features

- Tunnel mounts over existing conveyor (conveyor can also be supplied upon request)
- Swivel joint nozzles allow operator to adjust spray positioning
- Allen Bradley Photo Sensors automatically queue operation and shut off
- Type 304 Stainless Steel Frame & FDA approved plastics
- Completely enclosed frame with dustpan and vacuum port
- Plastic lined guide rails included
- Clear Lexan viewing panels allow for full visibility and access



E: sales@mcbradyengineering.com

T: 815-744-8900

www.mcbradyengineering.com

1251 S. Larkin Ave. Joliet, IL 60436



MCBRADY ENGINEERING, INC.

Experts in Bottle Cleaning Machinery, Engineering and Fabrication Services

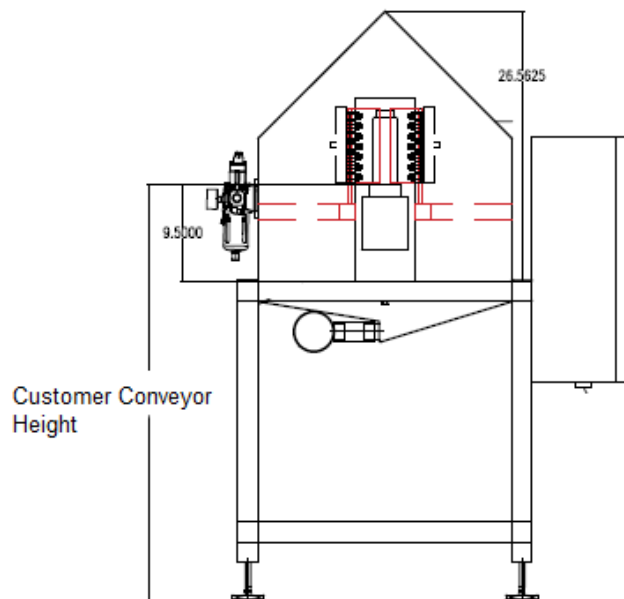
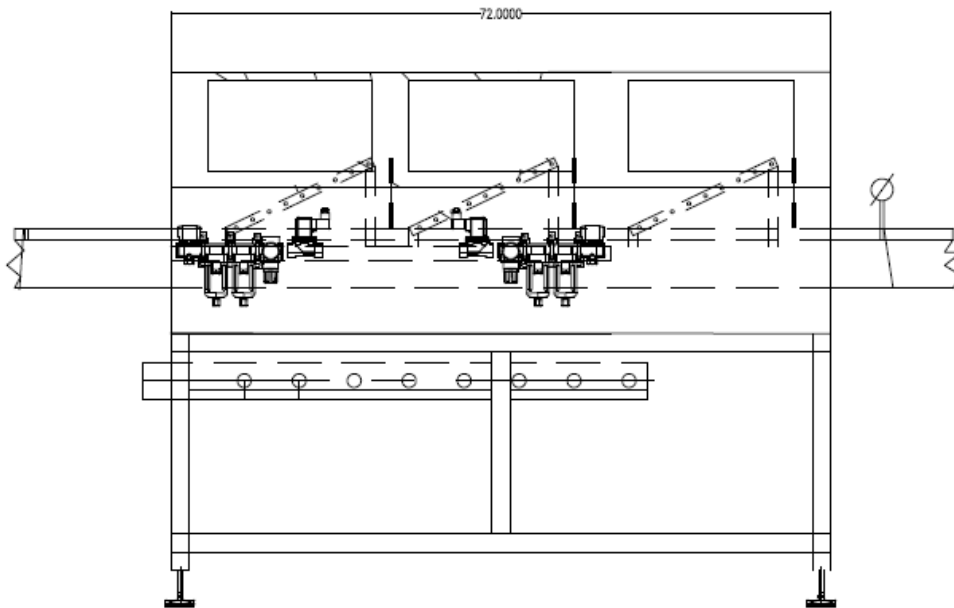

E: sales@mcbradyengineering.com

www.mcbradyengineering.com



T: 815-744-8900

1251 S. Larkin Ave. Joliet, IL 60436