



Experts in Bottle Cleaning Machinery, Engineering and Fabrication Services

## ORBIT BOTTLE CLEANER

With five unique models to choose from, there is an ORBIT for every container and bottle cleaning need. The ORBIT's design allows it to mount over your existing conveyor, leaving a small footprint and a simpler integration into the existing line. Direct tube injection of air, liquid, steam, or gas is utilized to thoroughly clean the inside of the bottle. This machine is also the perfect tool for gas purging/flushing the inside of new wine bottles prior to filling. This is the perfect cleaner for those looking to conserve space in their line.

### Special Features

- Bottles are inverted and **rinsed continuously** via direct tube injection into the neck of the bottle
- Bottles are not gripped, squeezed, or pushed, but rather **contained within a pocket**
- Mounts over existing conveyor to consume only **25"** of line space
- **Tool-less changeover**, requires only the interchanging of parts



E: [sales@mcbradyengineering.com](mailto:sales@mcbradyengineering.com)

T: 815-744-8900

[www.mcbradyengineering.com](http://www.mcbradyengineering.com)

1251 S. Larkin Ave. Joliet, IL 60436





Experts in Bottle Cleaning Machinery, Engineering and Fabrication Services

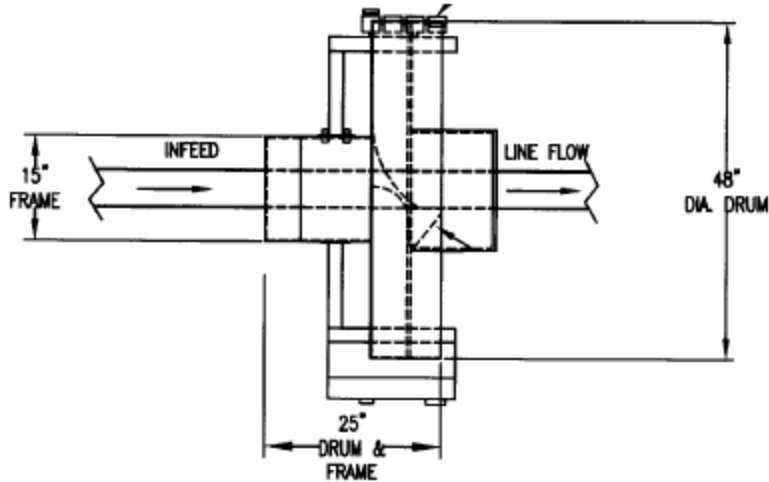

**Air Consumption:**

20-30cfm at 30-40 psi

**Water Consumption:**

10-20 gallons per minute

\*Actual utility consumption will vary\*

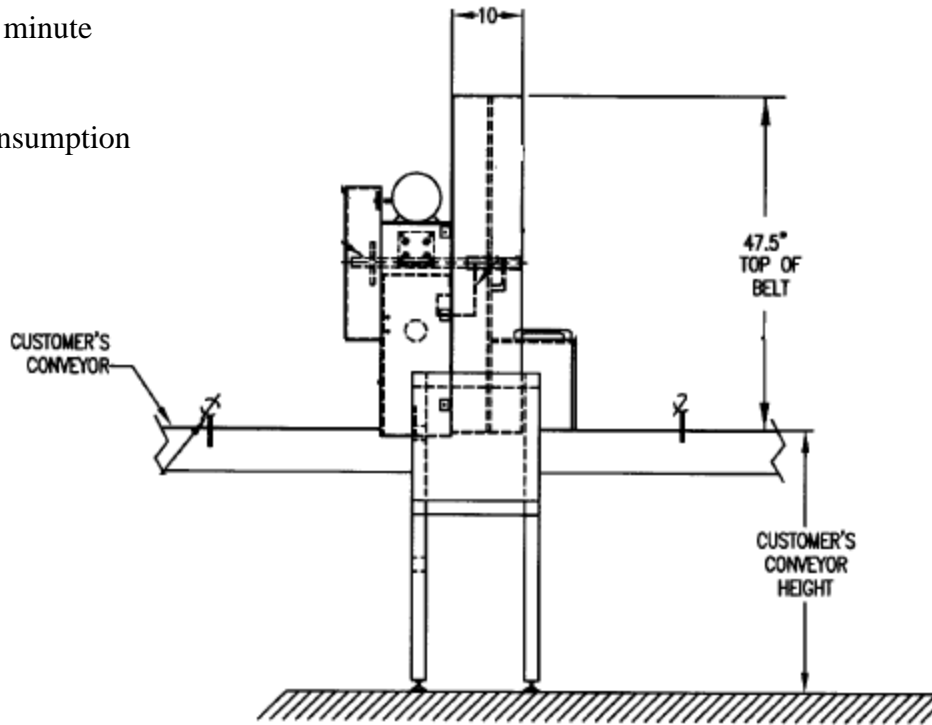

E: [sales@mcbradyengineering.com](mailto:sales@mcbradyengineering.com)

[www.mcbradyengineering.com](http://www.mcbradyengineering.com)

T: 815-744-8900

1251 S. Larkin Ave. Joliet, IL 60436

